

A-A SECTION

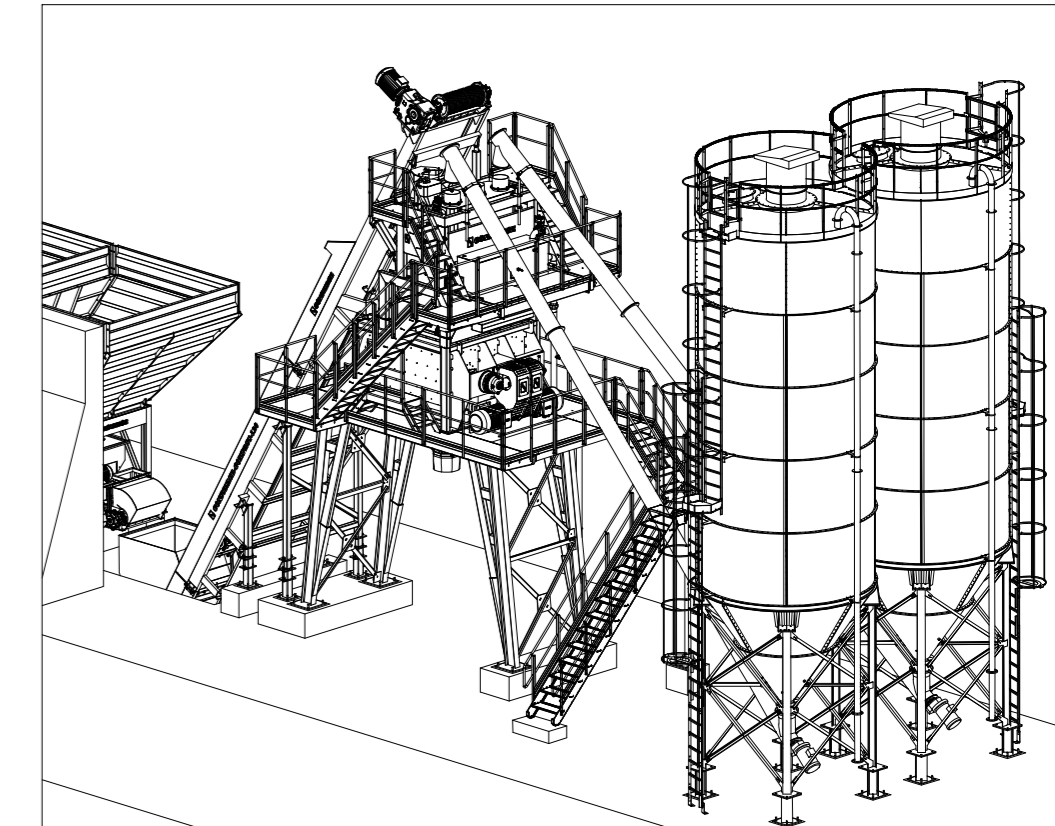
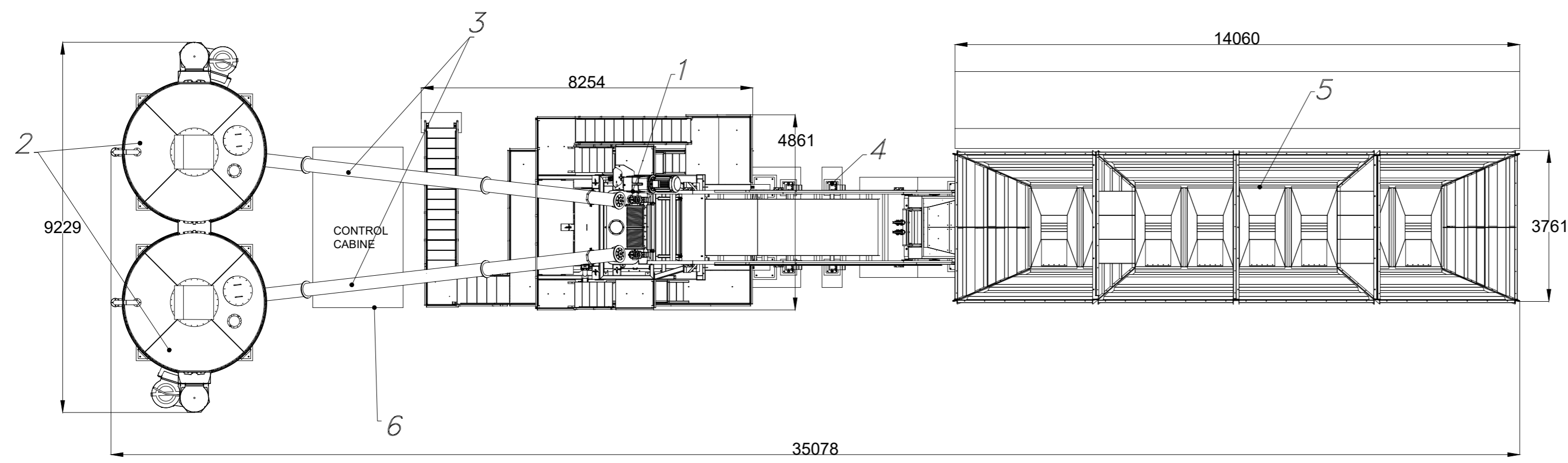
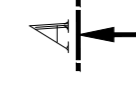

P. NO	COMPONENT NAME	QTY	METARIAL	DESCRIPTIONS	TOTAL MASS
6	CONTROL CABINE	1	-	-	-
5	AGGREGATE BUNKER	1	-	4*30 M <sup>3</sup> - 1000MM	-
4	TRANSFER	1	-	4.5 M <sup>3</sup> BUCKET LOADER	-
3	SCREW CONVEYOR	2	-	Ø323*14000MM	-
2	CEMENT SILO	2	-	100 TONS BOLTED	-
1	COMPACT 120	1	-	3M3 TWINSHAFT	-

P. NO COMPONENT NAME QTY METARIAL DESCRIPTIONS TOTAL MASS company

order number

**CONSTMACH**

name signature date: 24-08-2023 capacity 120M<sup>3</sup>

design T.KOKGIRAN plant name

drawn F.BILGIN

check EMRE CINAR

approved

scale ISO E-SIZE A1

CONSTMACH COMPACT 120 PLANT LAYOUT

sheet name

R.NO revision date name